

FULL LINE OF RADIATION SHIELDING PRODUCTS



Radiation Protection Products (RPP) manufactures a full line of radiation shielding products. They include Lead Lined Doors (solid core wood, lead lined, and steel strapped), Lead Lined Drywall (otherwise known as Lead Lined Sheetrock or Lead Lined Gypsum Wallboard) and Lead Lined Plywood, Leaded X-ray Glass, Lead Lined Frames for borrowed lites and doors, pass boxes and many other lead products.

We also manufacture and install Radiation Therapy Vault Doors (Neutron Doors) and Interlocking Lead Bricks.

Radiation Protection Products uses only the finest quality material and exercises the best quality control possible.

We offer a top quality line of lead shielding products at a competitive price with delivery to satisfy your needs. For additional information concerning RPP's products or services, please contact us toll free at:

888-746-4777 PHONE
866-554-8445 FAX

ALL SHIELDING PRODUCTS PROVIDED MEET THE FOLLOWING SPECIFICATIONS:

Sheet Lead

Sheet Lead shall meet or exceed the Federal Specification QQL-201 F Grade C and ASTM B749-03 Standard Specification for Lead and Lead Alloy Strip, Sheet and Plate Products, see NCRP reports #33, #35, #49 and #147.

Gypsum Board

Gypsum Board shall meet or exceed ASTM C1396, ASTM C840, and Federal Specification SS-L-30D Grade X Type III.

Leaded Glass

Leaded Glass shall meet or exceed Federal Specification DD-G-451.

Radiation Protection Products manufactures all lead shielding products in accordance with Lead Industries Hand Book and all NCRP Applicable Reports (#33, #35, #39, #40, #49 and #147) and NBS, HB. #114.

Cassette Transfer Cabinets

Cassette Transfer Cabinets shall meet or exceed MIL-C-3673 (DM).

Wood and Plastic Laminate Doors

All Wood Doors shall meet or exceed the ANSI/NWMA Industry Standard I.S.I.-80, I.S.I.4-80, NCRP Report #49.

TERMS AND CONDITIONS OF SALES

Prices in U.S. Dollars

Prices are in U.S. dollars, F.O.B. factory, Chapel Hill, Tennessee, unless otherwise specified. Prices, specifications, and terms of sales are subject to change without notice. All orders are subject to review prior to acceptance.

Terms

Net 30 days on established accounts with approved credit. Visa/MasterCard.

Credit

New accounts, pending credit approval, may be immediately expedited by enclosing a check, wire transfer or credit card. To facilitate opening of accounts, please forward your bank and four (4) trade references. Tax-exempt or Resale Certificate required if applicable.

Minimum

Minimum invoice of \$500.00. Orders under \$500.00 may require payment by Visa or MasterCard.

Ordering/Purchasing

Your purchase order or contract is requested on all orders. All orders should be confirmed and clearly marked "Confirmation—Do Not Duplicate."

Shipment

Unless detailed shipping instructions are specified on all orders, we reserve the right to choose the method of transportation and to make partial shipments, if necessary.

Packaging/Set Up Charge

Special packaging quoted as extra. Set up charges may be applicable with certain fabrications.

Returns

Return merchandise will be accepted only with prior written authorization. Freight charges must be prepaid.



1000 Superior Boulevard, Suite 310 • Wayzata, MN 55391
1.888.RINGRPP (1.888.746.4777) • TOLL FREE FAX: 1.866.554.8445
www.radiationproducts.com

servicing the nation's lead needs since 1952 with a full line of radiation shielding products

RADIATION SHIELDING LEAD LINED DOOR FRAMES

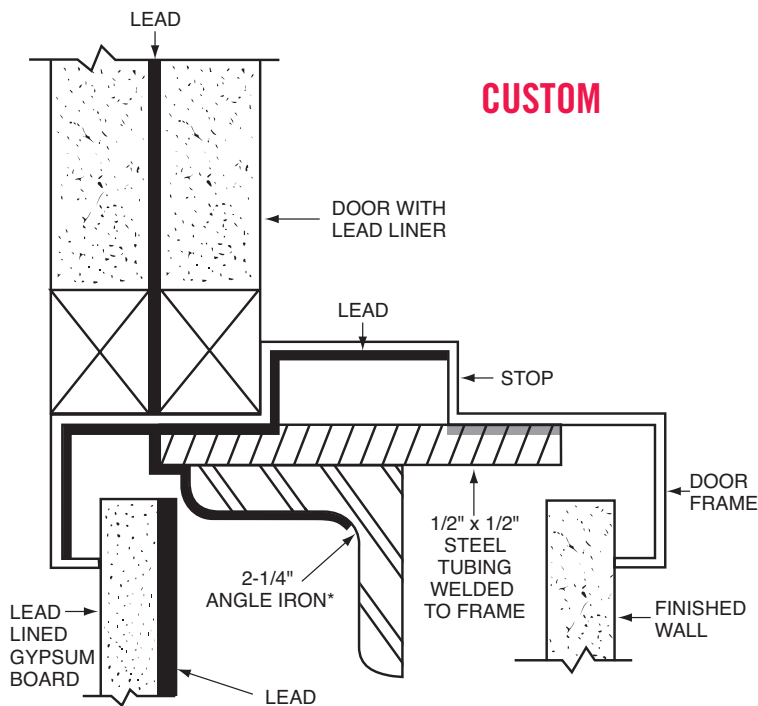
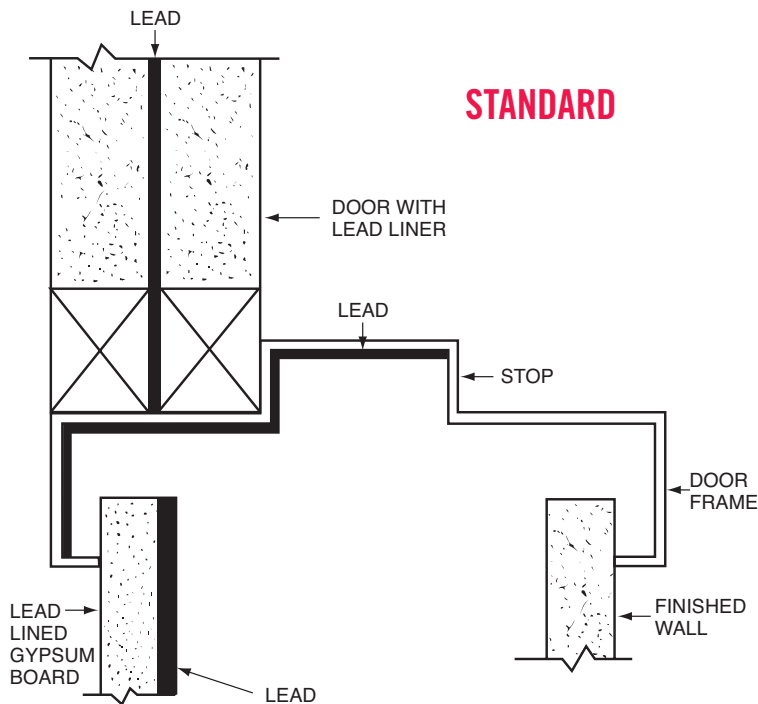

STANDARD LEAD LINED DOOR FRAMES

Radiation Protection Products' Standard Lead Lined Door Frames consist of 16-gauge steel, a 2" face, and a 5-7/8" jamb depth. They are set up and welded and can accommodate up to 1/2" thick lead lining. Our Lead Lined Door Frames are shipped with steel stud anchors that can be attached to the door frame either by welding or with steel fasteners if the lead lining does not exceed 3/32" thick.

We require the use of an Angle Iron for added support on Lead Lined Door Frames that require 1/8" thick lead or higher. These Angle Irons can be spot welded to the steel stud or pre-drilled and bolted to the steel stud.

*We do offer angle irons on our lead lined door frames that are below 1/8" thick lead if requested.

CUSTOM LEAD LINED DOOR FRAMES

We can supply knock down, slip and other lead lined frames upon request. Our Lead Lined Frames can also be equipped with the type of anchors necessary for any given situation (wood stud anchors, masonry strap anchors, etc.). Although our standard Lead Lined Door Frames consist of 16-gauge steel, we offer frames at 14-gauge and 12-gauge as well.

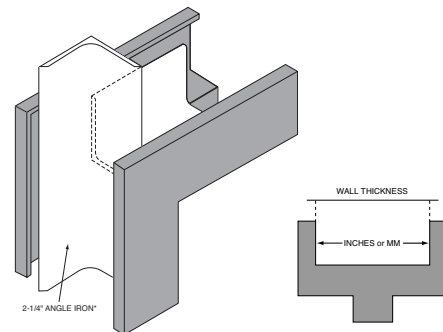

1000 Superior Boulevard, Suite 310 • Wayzata, MN 55391
1.888.RINGRPP (1.888.746.4777) • TOLL FREE FAX: 1.866.554.8445
www.radiationproducts.com

servicing the nation's lead needs since 1952 with a full line of radiation shielding products

The information contained on our website, submittals, specifications, etc... is offered for assistance in specifying products and materials from Radiation Protection Products, Inc. It is not intended to be complete and Radiation Protection Products, Inc. does not assume any responsibility for the adequacy of the submittals/specifications for a particular application. These submittals/specifications are subject to change without notice and without incurring obligation. Actual performance may vary in specific applications. An appropriate and qualified design professional/structural engineer must verify suitability of products for use in a particular application, as well as review final submittals/specifications. Radiation Protection Products, Inc.